

VAKA INTELLIGENT



[www.vakadesk.com](http://www.vakadesk.com)

Patent No.:  
S-series: 02330029076.7  
D-series: 202330027756.5  
Bed-series: 202330027566.3

**Vaka Intelligent Furniture Limited**

Add: Unit 2249 on 22 floor of 25-27 Wong Chuk Hang Road,  
Wong Chuk Hang, Hong Kong

**Vaka Intelligent Furniture (Ningbo) Co.,Ltd**

Add: Rongjiang Village, Jiangshan Town, Yinzhou District,  
Ningbo, Zhejiang, China

**Vaka Intelligent Furniture (Guangzhou) Co.,Ltd**

Add: Room 303, Creative Center, No.69 Guangpu West Road,  
Huangpu District, Guangzhou, China

Web: [www.vakadesk.com](http://www.vakadesk.com)  
Email: [info@vakadesk.com](mailto:info@vakadesk.com)  
Tel: +86-20-89859924

# VAKA

## Electric Lifting Systems

To be the most trustworthy supplier and partner in  
the height adjustable desk industry



VAKA INTELLIGENT FURNITURE (GUANGZHOU) CO., LTD.



VAKA

ELECTRIC LIFTING SYSTEMS



# VAKA Intelligent Furniture



Vaka Intelligent Furniture is a professional manufacturer of intelligent height adjustable office and home desks. Founded in 2015, we specialize in design, development, production and sales of height adjustable desks. And we are good at the development of electrical systems including control boxes, linear actuators, and motors. With rich experience in ODM & OEM, SCM optimization, lean production, and scale effect, Vaka can provide competitive products, and Vaka desks have been well-recognized in over 50 countries.

Guaranteed quality originates from Taiwan.

By adopting Taiwan original design and exquisite technology, we make the posture more healthy and comfortable when working & studying, and also make the office and home full of infinite imagination.

Using 3D laser cutting machines ensures standard cutting speed and quality. Taiwan standard automatic spraying line guarantees the consistency of spraying thickness and customizes the desired colors for the clients.

The integrated machines of assembly and testing can respond to whether the assembly is good by calculating the damping value while assembling the desk legs.

80% automation equipment, not only ensures high quality, high efficiency, and low cost, but not badly wastes both time and cost for our clients.

The basic tenet of Vaka is that quality is the foundation of our product's value and dignity. We are proud of being recognized by our strong partners. And we will continuously provide perfect customized solutions for intelligent office and home furniture.

**Mission**  
To improve the study and work environment with users together

**Vision**  
To be the most trustworthy supplier and partner in the height adjustable desk industry

## CONTENTS

### Office Part

2-leg straight desks series	05
3-leg corner desks series	06
Face-to-face workstations series	07
Meeting desks series	08
E-commerce desks series	09
Standing desk converters series	10

### Home Part --Volex

1-leg home office/study desks series	12
2-leg home office/study desks series	13
Height adjustable loft beds series	14
Height adjustable side tables series	15



## 2-leg straight desks series

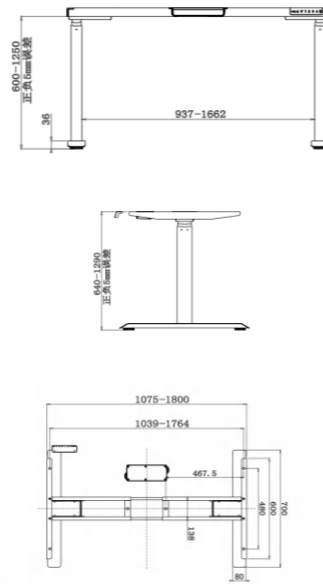

Items	Motors	Stages	Tube shape	Column shape	Control system brand
Options	1 / 2 motors	2 / 3 stages	Square / Rectangular / Round / Elliptical	Upwards / Downwards	Timotion / SAJ / Vaka

**Model: T320**  
 Product name: Dual-motor straight desk  
 Control system brand: Timotion  
 Height range: 640—1290mm  
 Speed: 40mm/S  
 Noise rate: <39DB  
 Max loading: 150kg  
 G.W.: 30.5kg

**Model: M320 / U320**  
 Product name: Dual-motor straight desk  
 Control system brand: SAJ / Vaka  
 Height range: 610—1260mm / 640—1290mm  
 Speed: 32mm/S  
 Noise rate: <49DB  
 Max loading: 120kg  
 G.W.: 29.5kg

**Model: M220**  
 Product name: Single-motor straight desk  
 Control system brand: SAJ  
 Height range: 740—1240mm / 710—1160mm  
 Speed: 25mm/S  
 Noise rate: <49DB  
 Max loading: 90kg  
 G.W.: 25kg

### Case



## 3-leg corner desks series

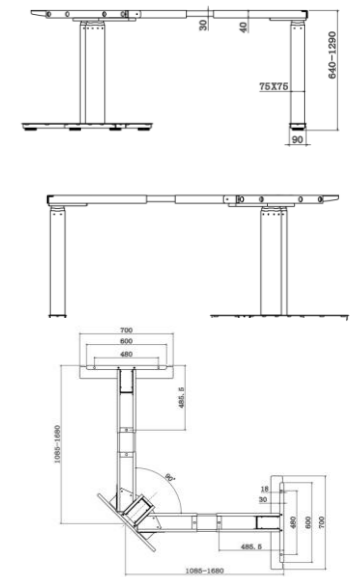

Items	Corner degree	Tube shape	Column shape	Control system brand
Options	90° / 120° / 180°	Square / Rectangular / Round / Elliptical	Upwards / Downwards	Timotion / SAJ / Vaka

**Model: T330**  
 Product name: 3-motor L-shape corner desk  
 Control system brand: Timotion  
 Height range: 640—1290mm  
 Speed: 35mm/S  
 Noise rate: <39DB  
 Max loading: 160kg  
 G.W.: 56k

**Model: U330**  
 Product name: 3-motor L-shape corner desk  
 Control system brand: SAJ / Vaka  
 Height range: 640—1290mm  
 Speed: 32mm/S  
 Noise rate: <49DB  
 Max loading: 150kg  
 G.W.: 52kg

### Case

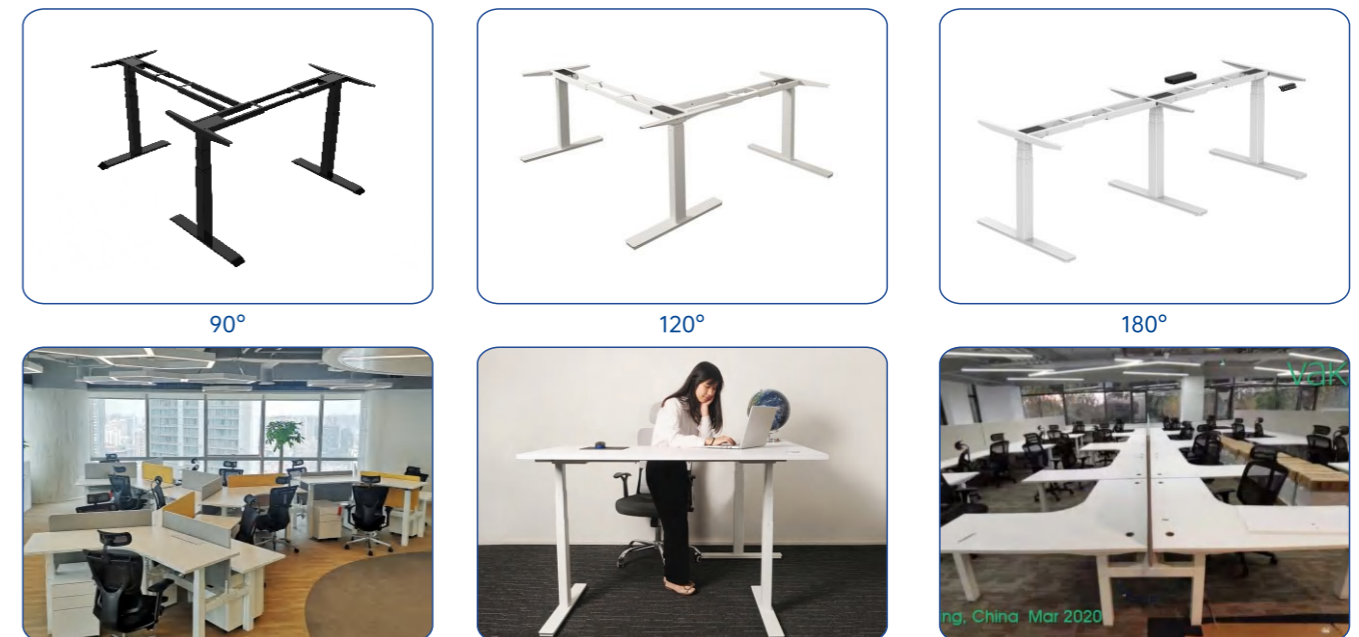



## Face-to-face workstations series

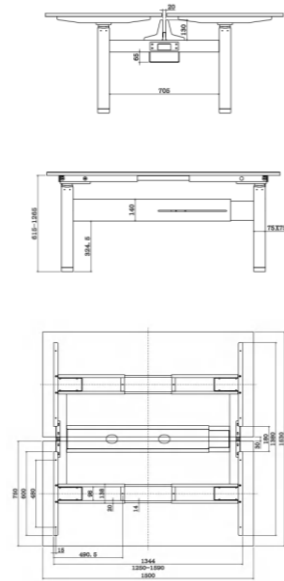

Items	Motors	Stages	Tube shape	Column shape	Control system brand
Options	2 / 4 motors	2 / 3 stages	Square / Rectangular / Round / Elliptical	Upwards / Downwards	Timotion / SAJ / Vaka

**Model: T340**  
 Product name: 4-motor face-to-face workstations  
 Control system brand: Timotion  
 Height range: 640—1290mm  
 Speed: 40mm/S  
 Noise rate: <39DB  
 Max loading: 2\*120kg  
 G.W.: 76kg

**Model: U340**  
 Product name: 4-motor face-to-face workstations  
 Control system brand: SAJ / Vaka  
 Height range: 610—1260mm / 640—1290mm  
 Speed: 32mm/S  
 Noise rate: <49DB  
 Max loading: 2\*100kg  
 G.W.: 72kg

### Case

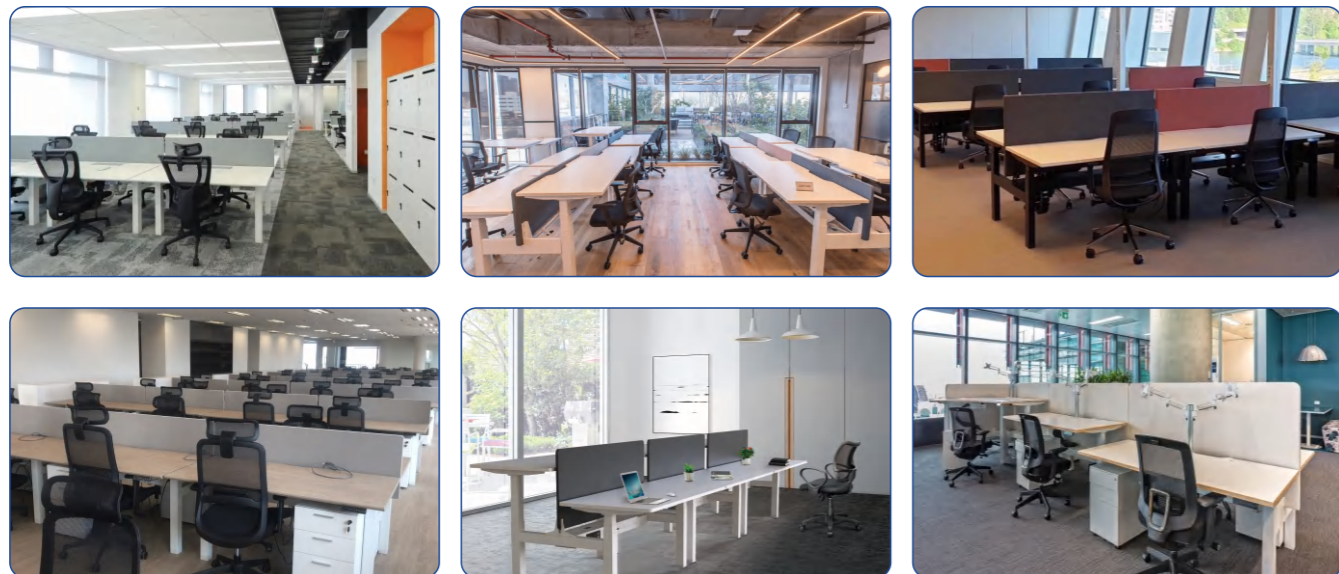

## Meeting desks series



**Model: T130**  
 Product name: Single-motor meeting desk  
 Control system brand: Timotion  
 Height range: 710—1170mm / 650—1300mm  
 Speed: 25mm/S | 32mm/S  
 Noise rate: <39DB  
 Max loading: 60kg

**Model: T430**  
 Product name: 4-motor meeting desk / boss desk  
 Control system brand: Timotion  
 Height range: 640—1290mm  
 Speed: 40mm/S  
 Noise rate: <39DB  
 Max loading: 200kg

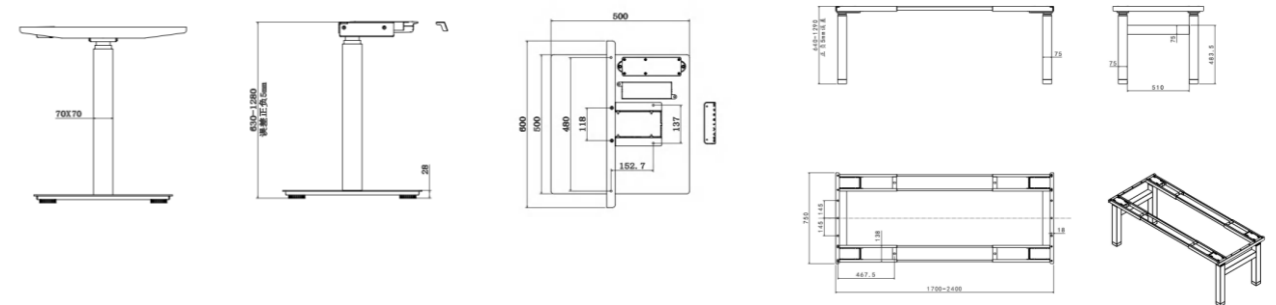

### Case



## E-commerce desks series



Model: E222-S

Product name: Single-motor straight desk

Height range: 710—1180mm

Speed: 23mm/S

Noise rate: <49DB

Max loading: 80kg

G.W.: 20.5kg

Model: E221-D

Product name: Dual-motor straight desk

Height range: 730—1200mm

Speed: 25mm/S

Noise rate: <49DB

Max loading: 90kg

G.W.: 25kg

Case

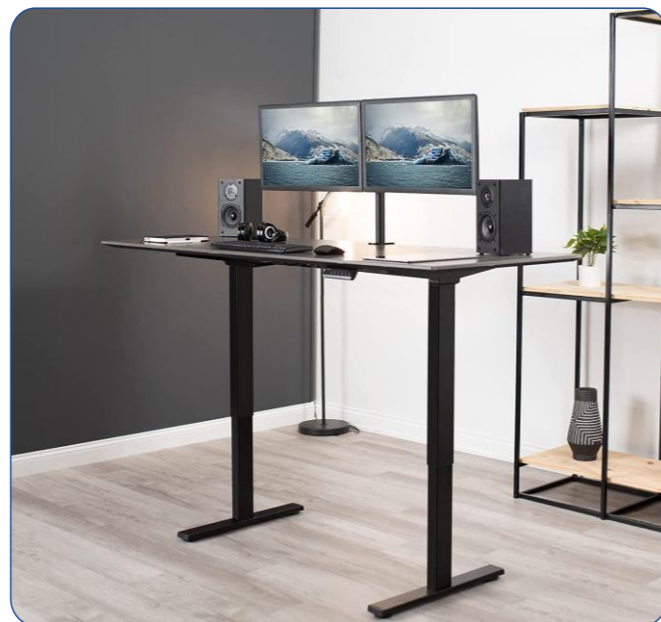
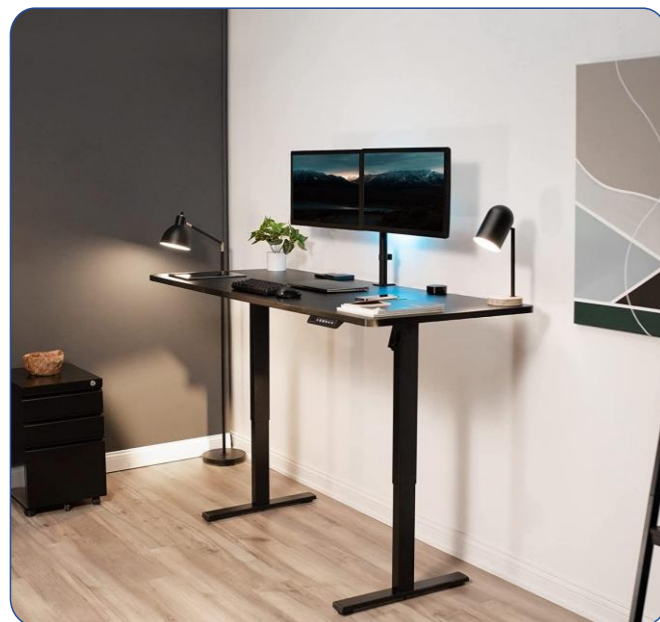

## Standing desk converters series



TT202



TT200



TT201

### Office Accessories



Desktop



Cable Tray



CPU Holder



Screen Panel



Cable Tray



Cable Box

Case

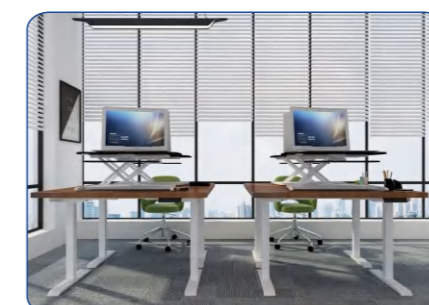
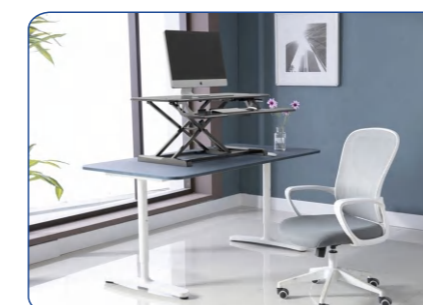



# Home Part --Volex



# 1-leg home office/study desks series

	<b>S01 1-leg Wall-mount Desk Frame</b>	
	S01-All work-from-home desk Height range:640-1290mm Speed:32mm/S	S01-All kids' studying desk Height range: 450-870mm Speed: 25mm/S
Noise rate: <49DB Max loading: 40kg Available voltage: 100V-240V; 50/60Hz Suitable desktop size: W(500-700)mm * D(400-600)mm		

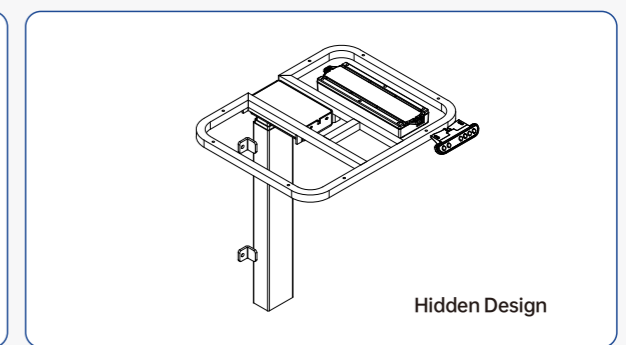
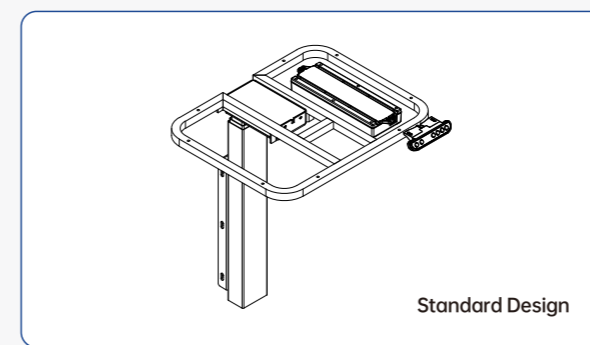

### Case

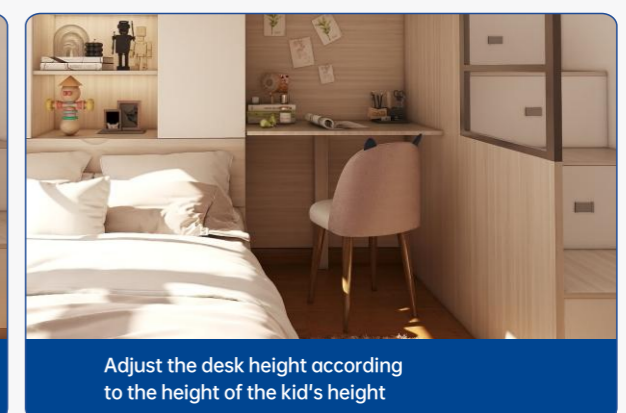
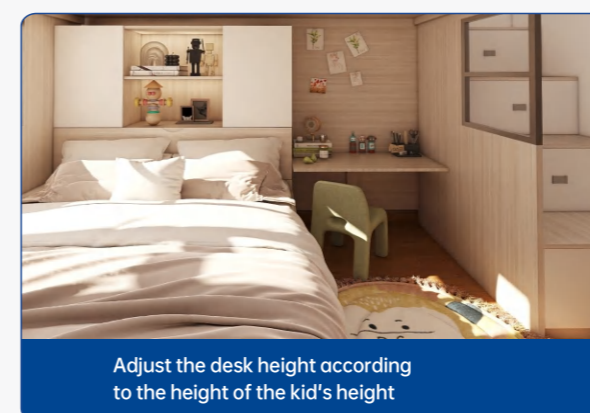
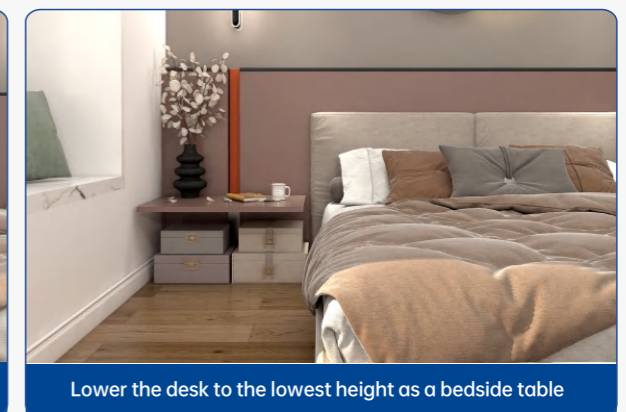
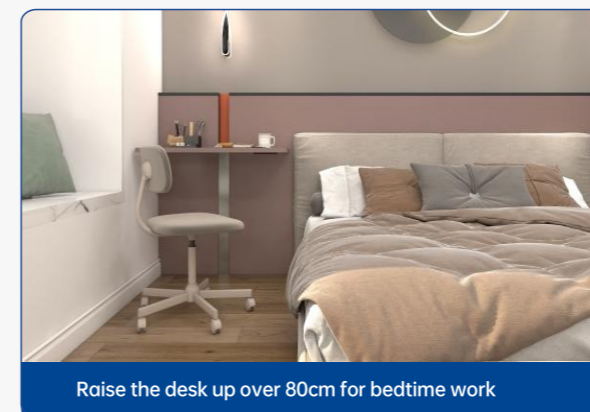

## 2-leg home office/study desks series

	<b>D02 2-leg Wall-mount Desk Frame</b>	
	D02-AI work-from-home desk Height range: 640-1290mm Speed: 32mm/S	D02-All kids' studying desk Height range: 450-870mm Speed: 25mm/S
	Noise rate: <49DB Max loading: 80kg Available voltage: 100V-240V; 50/60Hz Suitable desktop size: W(1000-1800)mm * D(500-750)mm	

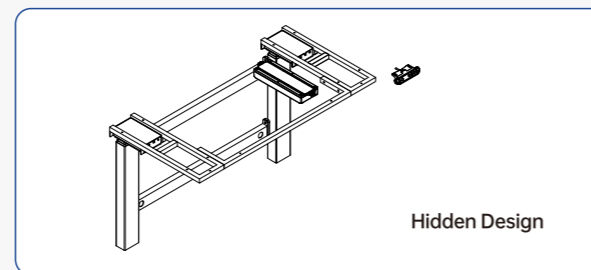
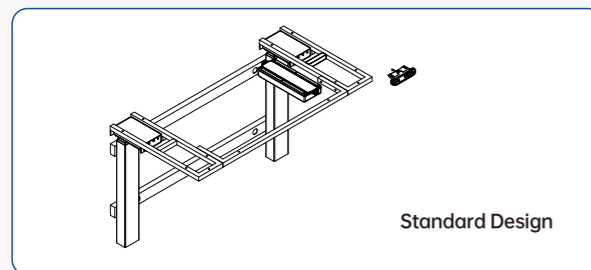

Case



Sitting play games / study



Standing play games / study



One desk throughout the whole schoolhood

450-870mm adjustable height fits with the desk height from kindergarten to university perfectly  
Hidden the desk feet in the wallboard. Integrated and more aesthetic

## Height adjustable loft beds series

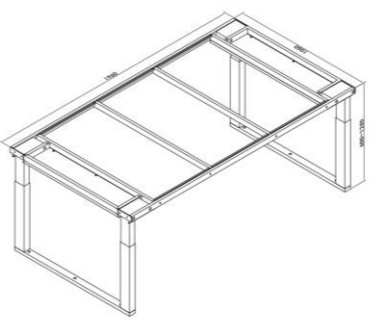
	<b>B01</b> Electric Height Adjustable Loft Bed Frame
	Model: B01 Frame size: W(1900-2050)mm * D(900-1500)mm Height range: 600-1250mm Speed: 20mm/S Noise rate: <49DB Max loading: 200kg Available voltage: 100V-240V; 50/60Hz

Case

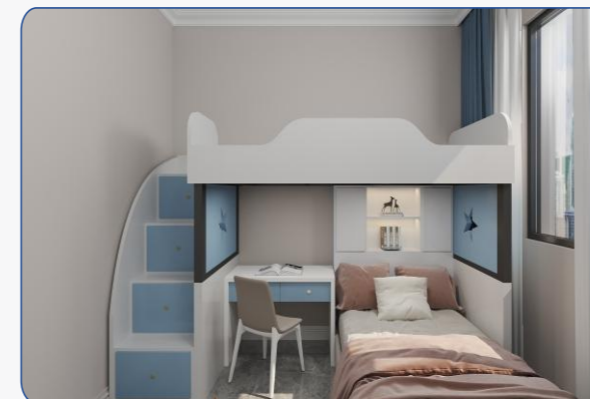

Bedtime: Lower the bed to the lowest height (like a traditional loft bed)



Work/study time: Raise the bed up over 2m, adults and children can stand under the bed without problems



Small Spaces, Big Dreams

Never sacrifice style or comfort even if the room is only 5-8m<sup>2</sup>  
Applications: Small bedrooms with low ceilings



## Height adjustable side tables series



Model: SD100  
Product name: Height Adjustable Side Table  
Tabletop size: W700mm \* D400mm  
Height range: 650—970mm  
Max loading: 15kg

### Case



## Dest frame options



## Control system options



Welcome OEM/ODM Projects

# Proven Technique & Guaranteed Quality

Over 20000times lifting tests passed  
Over 5 global authoritative quality certificates



## Germany quality motor

Adopt the motor from the same contract manufacturer Envision as Germany OMT  
The noise rate < 49db is smaller than that of refrigerators



## SAJ control box

Develop and produce the control box jointly with SAJ  
The advanced chip control system with sensitive reaction and no stuttering



# Office Part

Model	E222-S	M220	E221-D	M320 / U320	T320
<b>Product name</b>	Single-motor straight desk	Single-motor straight desk	Dual-motor straight desk	Dual-motor straight desk	Dual-motor straight desk
<b>Drive mode</b>	1 motor	1 motor	2 motors	2 motors	2 motors
<b>Stages</b>	2 stages	2 stages	2 stages	3 stages	3 stages
<b>Max loading</b>	80kg	90kg	90kg	120kg	150kg
<b>Speed</b>	23mm/S	25mm/S	32mm/S	32mm/S	40mm/S
<b>Noise rate</b>	< 49DB	< 49DB	< 49DB	< 49DB	< 39DB
<b>Height range</b>	710-1180mm / Customized	740-1240mm / 710-1160mm / Customized	730-1200mm / Customized	610-1260mm / Customized	640-1290mm / Customized
<b>Beam</b>	Single beam 900-1300mm(W)	Double beams 1075-1600mm(W)	Double beams 990-1600mm(W) / Customized	Double beams 1010-1700mm(W) / Customized	Double beams 1075-1800mm(W) / Customized
<b>Bracket</b>	450mm(L) / Customized	575mm(L) / Customized	560mm(L)/Customized	575mm(L)/Customized	600mm(L) / Customized
<b>Tube shape &amp; size</b>	Square 75*75mm Rectangular 75*45mm	Square 75*75mm Rectangular 80*50mm	Square 75*75mm Rectangular 80*50mm	Square 75*75mm Rectangular 80*50mm	Square 75*75mm Rectangular 80*50mm
<b>Column shape</b>	Upwards / Downwards	Upwards / Downwards	Downwards	Upwards / Downwards	Upwards / Downwards
<b>Desk foot</b>	Slope / Flat shape 550mm(L) / Customized	Slope / Flat shape 700mm(L) / Customized	Slope / Flat shape 600mm(L)/Customized	"Slope / Flat shape 700mm(L)/Customized	Slope / Flat shape 700mm(L) / Customized
<b>Thickness of painting</b>	60-100µm	60-120µm	60-100µm	60-120µm	60-120µm
<b>Colors</b>	White / Black / Grey Customized	White / Black / Grey Customized	White / Black / Grey Customized	White / Black / Grey Customized	White / Black / Grey Customized
<b>Functions options</b>	Anti collision Max & min height reset	Anti collision Safety child lock Max & min height reset	Anti collision Max & min height reset	Anti collision Safety child lock Max & min height reset	Anti collision Max & min height reset
<b>Available voltage</b>	100V-240V; 50/60Hz	100V-240V; 50/60Hz	100V-240V; 50/60Hz	100V-240V; 50/60Hz	100V-240V; 50/60Hz
<b>Control systems brand</b>	Vaka / SAJ	Vaka / SAJ	Vaka / SAJ	Vaka / SAJ	Timotion
<b>Certificate</b>	CE, SAA, RoHS, CUL, BIFMA	CE, SAA, RoHS, CUL, BIFMA	CE, SAA, RoHS, CUL, BIFMA	CE, SAA, RoHS, CUL, BIFMA	CE, SAA, RoHS, CUL, BIFMA
<b>G.W.</b>	18.5kg	25kg	25kg	29.5kg	30.5kg
<b>Package size</b>	113* 23* 20cm	108 * 27 * 24cm	93 * 35 * 16cm	Box A: 77.5 * 28 * 13.5cm Box B: 108 * 26 * 9.5cm	108 * 32 * 22cm
<b>QTY in 20GP (With pallets)</b>	360pcs	320pcs	360pcs	288pcs	288pcs
<b>QTY in 40HQ (With pallets)</b>	1008pcs	720pcs	1008pcs	845pcs	720pcs
<b>Warranty</b>	3years	5years	3years	5years	5years
<b>Suitable tabletop size</b>	1000-1400mm(W)	1100-1600mm(W)	1000-1600mm(W)	1100-1800mm(W)	1100-2000mm(W)



# Office Part

Model	U330	T330	U340	T340
<b>Product name</b>	3-motor L-shape corner desk	3-motor L-shape corner desk	Face-to-face workstations	Face-to-face workstations
<b>Drive mode</b>	3 motors	3 motors	4 motors	4 motors
<b>Stages</b>	3 stages	3 stages	3 stages	3 stages
<b>Max loading</b>	150kg	160kg	2*100kg	2*120kg
<b>Speed</b>	32mm/S	35mm/S	32mm/S	40mm/S
<b>Noise rate</b>	< 49DB	< 39DB	< 49DB	< 39DB
<b>Height range</b>	610-1260mm / Customized	640-1290mm / Customized	610-1260mm / Customized	640-1290mm / Customized
<b>Beam</b>	Double beams Main frame: 1100-1700mm(W) Side frame: 1380-2080mm(W)	Double beams Main frame: 1075-1800mm(W) Side frame: 1375-1800mm(W)	Double beams 1010-1700mm(W)/ Customized	Double beams 1075-1800mm(W) / Customized
<b>Bracket</b>	575mm(L) / Customized	600mm(L) / Customized	575mm(L) / Customized	600mm(L) / Customized
<b>Tube shape &amp; size</b>	Square 75*75mm Rectangular 80*50mm*	Square 75*75mm Rectangular 80*50mm	Square 75*75mm Rectangular 80*50mm	Square 75*75mm Rectangular 80*50mm
<b>Column shape</b>	Upwards / Downwards	Upwards / Downwards	Upwards / Downwards	Upwards / Downwards
<b>Desk foot</b>	Slope / Flat shape 700mm(L) / Customized	Slope / Flat shape 700mm(L) / Customized	Slope / Flat shape 700mm(L) / Customized	Slope / Flat shape 700mm(L) / Customized
<b>Thickness of painting</b>	60-120µm	60-120µm	60-120µm	60-120µm
<b>Colors</b>	White / Black / Grey / Customized	White / Black / Grey / Customized	White / Black / Grey / Customized	White / Black / Grey / Customized
<b>Functions options</b>	Anti collision Safety child lock Max & min height reset	Anti collision Safety child lock Max & min height reset	Anti collision Safety child lock Max & min height reset	Anti collision Max & min height reset
<b>Available voltage</b>	100V-240V; 50/60Hz	100V-240V; 50/60Hz	100V-240V; 50/60Hz	100V-240V; 50/60Hz
<b>Control systems brand</b>	Vaka / SAJ	Timotion	Vaka / SAJ	Timotion
<b>Certificate</b>	CE, SAA, RoHS, CUL, BIFMA	CE, SAA, RoHS, CUL, BIFMA	CE, SAA, RoHS, CUL, BIFMA	CE, SAA, RoHS, CUL, BIFMA
<b>G.W.</b>	52kg	56kg	72kg	76kg
<b>Package size</b>	Box A: 108 * 45 * 14cm Box B: 79 * 44 * 17cm	Box A: 88 * 48 * 14cm Box B: 138 * 32 * 20cm	2* Box A: 108 * 28 * 25cm 1* Box B: 129 * 32 * 12cm	2 * Box A: 108 * 32 * 28cm 1 * Box B: 126 * 54 * 15cm
<b>QTY in 20GP (With pallets)</b>	208pcs	208pcs	78pcs	78pcs
<b>QTY in 40HQ (With pallets)</b>	540pcs	540pcs	190pcs	190pcs
<b>Warranty</b>	5years	5years	5years	5years
<b>Suitable tabletop size</b>	1400-2000mm(W)	1400-2000mm(W)	1100-1700mm(W)	1100-1800mm(W)

# Office Part

Model	TT202	TT200	TT201
<b>Product name</b>	Standing desk converter	Standing desk converter	Standing desk converter
<b>Drive mode</b>	Gas spring lifting	Gas spring lifting	Gas spring lifting
<b>Max loading</b>	Desktop:15kg Keyboard tray: 2kg	Desktop:15kg Keyboard tray: 2kg	Desktop:15kg Keyboard tray: 2kg
<b>Height range</b>	110—500mm	107—500mm	110—505mm
<b>Desktop size</b>	950 * 460mm / Customized	800 * 400mm / Customized	600 * 400mm / Customized
<b>Keyboard tray size</b>	945 * 300mm / Customized	795 * 300mm / Customized	595 * 300mm / Customized
<b>Colors</b>	White / Black	White / Black	White / Black
<b>G.W.</b>	15.5kg	13kg	11kg
<b>Package size</b>	105 * 56 * 18cm	88 * 54 * 15cm	88 * 52 * 15cm
<b>QTY in 20GP (With pallets)</b>	240pcs	312pcs	312pcs
<b>QTY in 40HQ (With pallets)</b>	520pcs	720pcs	720pcs
<b>Warranty</b>	5years	5years	5years

# Home Part--Volex

Model	S01-AI	S01-AII	D02-AI	D02-AII
<b>Product name</b>	Wall-mount sit-stand working desk	Wall-mount kids' studying desk	Wall-mount sit-stand working desk	Wall-mount kids' studying desk
<b>Drive mode</b>	1 motor	1 motor	2 motors	2 motors
<b>Stages</b>	3 stages	3 stages	3 stages	3 stages
<b>Max loading</b>	40kg	40kg	80kg	80kg
<b>Speed</b>	32mm/S	25mm/S	32mm/S	25mm/S
<b>Noise rate</b>	< 49DB	< 49DB	< 49DB	< 49DB
<b>Height range</b>	640-1290mm / Customized	450-870mm / Customized	640-1290mm / Customized	450—870mm / Customized
<b>Frame size</b>	480mm(W) * 380mm(D) / Customized	490mm(W) * 390mm(D) / Customized	1080mm(W) * 480mm(D) / Customized	1080mm(W) * 480mm(D) / Customized
<b>Tube shape &amp; size</b>	Square 75*75mm Rectangular 80*50mm	Square 75*75mm Rectangular 80*50mm	Square 75*75mm Rectangular 80*50mm	Square 75*75mm Rectangular 80*50mm
<b>Column shape</b>	Upwards	Upwards	Upwards	Upwards
<b>Thickness of painting</b>	60-120µm	60-120µm	60-120µm	60-120µm
<b>Colors</b>	White / Black / Grey / Customized	White / Black / Grey / Customized	White / Black / Grey / Customized	White / Black / Grey / Customized
<b>Functions options</b>	Anti collision Safety screen lock Max & min height reset	Anti collision Safety screen lock Max & min height reset	Anti collision Safety screen lock Max & min height reset	Anti collision Safety screen lock Max & min height reset
<b>Available voltage</b>	100V-240V; 50/60Hz	100V-240V; 50/60Hz	100V-240V; 50/60Hz	100V-240V; 50/60Hz
<b>Control systems brand</b>	SAJ / Vaka	SAJ / Vaka	SAJ / Vaka	SAJ / Vaka
<b>Certificate</b>	CE, SAA, RoHS, CUL, BIFMA	CE, SAA, RoHS, CUL, BIFMA	CE, SAA, RoHS, CUL, BIFMA	CE, SAA, RoHS, CUL, BIFMA
<b>G.W.</b>	15.5kg	13kg	30.5kg	26.5kg
<b>Warranty</b>	5years	5years	5years	5years
<b>Suitable tabletop size</b>	W(500-700)mm * D(400-600)mm	W(500-700)mm * D(400-600)mm	W(1100-1800)mm * D(500-750)mm	W(1100-1800)mm * D(500-750)mm

# Home Part--Volex

Model	B01
<b>Product name</b>	Height Adjustable Loft Bed Frame
<b>Drive mode</b>	4 motors
<b>Stages</b>	3 stages
<b>Frame size</b>	L(1900-2050)mm * W(900-1500)mm / Customized
<b>Max loading</b>	200KG
<b>Speed</b>	20mm/S
<b>Noise rate</b>	<49DB
<b>Height range</b>	1400-2050mm / Customized
<b>Colors</b>	White / Black / Grey / Customized
<b>Available voltage</b>	100V-240V; 50/60Hz
<b>Control systems brand</b>	SAJ / Vaka
<b>Warranty</b>	5years